



## DX1002-T

The DX modular housing arrangement offers a flexible and space conscious solution to integrate our innovative DXO Cartridge in to both new and existing systems. The Delta-Xero system can be configured up to 12 cartridges in parallel as a single unit in a compact and easily maintainable layout.

The unit can be supplied with a number of standard options to provide an effective fluid conditioning and monitoring package to suit the majority of systems. The flexibility of the unit allows tailoring to customer's specific requirements.



### DX1002-T

Drive Input	Electric or Pneumatic
Connection Ports	3/8" BSP In & Out
Flow Indicator	Visual
Suggested System Volume	Up to 9000l @ 32cSt
Particulate Removal	From 0.1 μ
Weight	25 kg
Dimensions	H 916 mm x D 300 mm x L 550 mm
Material	SS316
DXO Cartridge QTY	2

Flow Rate varies depending on viscosity, pressure and temperature

Approx flow at 2.7 bar:	32 cSt	46 cSt	68 cSt	100 cSt	220 cSt	320 cSt	460 cSt
Oil Volume	9000ltrs	7000ltrs	6000ltrs	4800ltrs	3600ltrs	1600ltrs	800ltrs

## General Arrangement

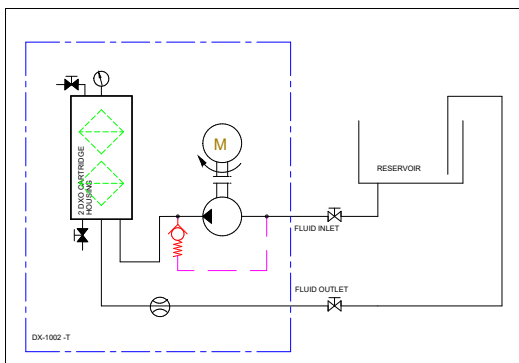
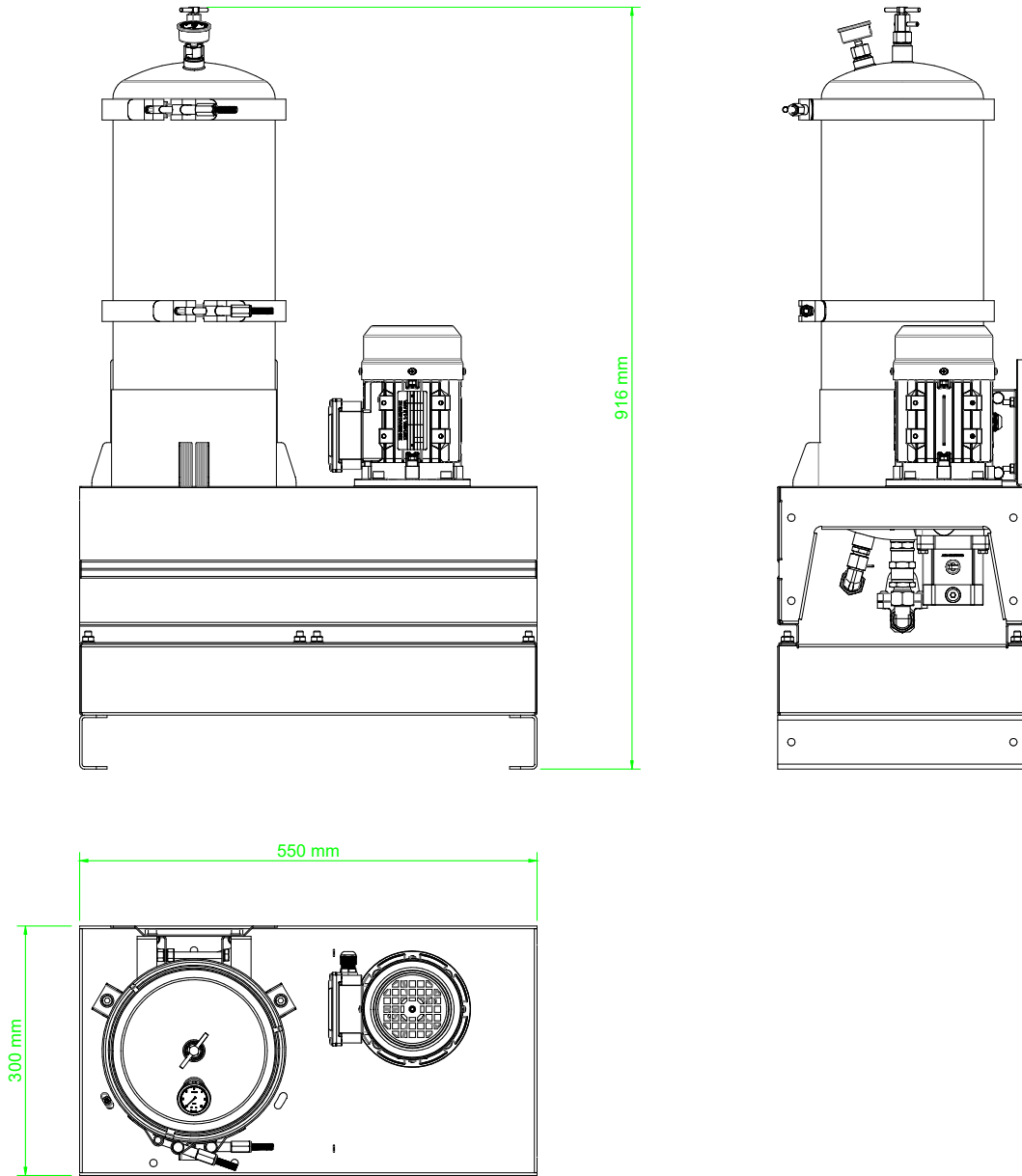

### DXO Cartridge

Contamination capacity:	Up to 4.5kg per DXO
Water absorption, free and bound:	2600ml
Material Insert:	PP Cellulose mix

