

# Triplex Plungerpumpe K 10000 – 3G

## Triplex Plunger Pump

P 15-1

30.05.2015

- Förderstromangaben mit 100% volumetrischem Wirkungsgrad und 20°C Umgebungstemperatur
- Mindestvordrücke je nach Fördermedium
- Drehzahlbereich 10-100% je nach Stangenkraft
- Getriebe dynamisch gewuchtet
- Getriebe mit Zwangsschmierung (> 110 kW mit Ölkühler)
- Standard Getriebeuntersetzungen  
i = 3,00 - 3,14 - 3,39 - 3,76 - 4,13 - 4,50 - 4,93
- Auch nach API 674 lieferbar
- Sondermedien wie Seewasser, Glykol, Methanol, Öle, etc. auf Anfrage

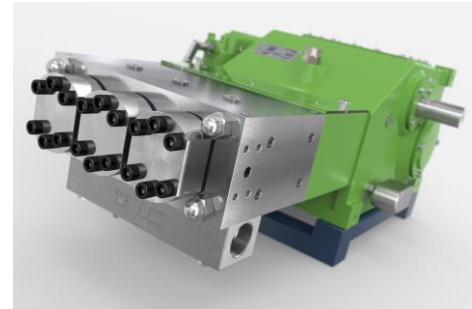

- Flow rate is based on 100% volumetric efficiency and 20°C ambient temperature
- min. inlet pressure depending on fluid medium
- Speed range 10-100% depending on rod force
- Gear dynamically balanced
- Gear with force-fed lubrication (> 110 kW with oil cooler)
- Standard gear ratios  
i = 3,00 - 3,14 - 3,39 - 3,76 - 4,13 - 4,50 - 4,93
- Also available to API 674

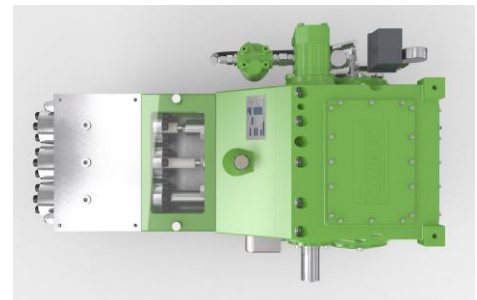

Special medium such as sea water, glycol, methanol, oils, etc. on request

n <sub>nom</sub> = 475 1/min		p max. bar @ kW				Kopftyp / Head type		
Typ / Type	l/min	75 kW	90 kW	110 kW	130 kW	A	M	MC
K 10012 – 3G	15	2600	3120	3500	-----	1		
K 10014 – 3G	21	1900	2270	2780	3300	1		
K 10016 – 3G	27	1470	1770	2160	2500	1		
K 10018 – 3G	34	1170	1405	1715	2050	1		
K 10020 – 3G	43	925	1110	1360	1630	1		
K 10022 – 3G	51	775	935	1140	1370	1		
K 10024 – 3G	61	650	780	955	1150	1		
K 10026 – 3G	72	550	665	810	975	1		H
K 10028 – 3G	83	480	575	700	845	1		H
K 10030 – 3G	96	415	500	605	730	1		H
K 10032 – 3G	109	365	440	535	645	1		H
K 10036 – 3G	138	290	345	420	510	1	1	H
K 10040 – 3G	170	235	280	345	415		1	1
K 10045 – 3G	215	185	220	270	330		1	1
K 10050 – 3G	266	150	180	220	265		1	1
K 10055 – 3G	321	125	150	180	220		1	1
K 10060 – 3G	383	105	125	150	185		1	1
K 10065 – 3G	449	90	105	130	160			1

API 674 = max. 450 1/min

= Ultra High Pressure UHP

Maßzeichnung K 10000 - 3G  
Dimension drawing

~ 440 kg

P 15-2

01.05.2017

Typ A  
Type A

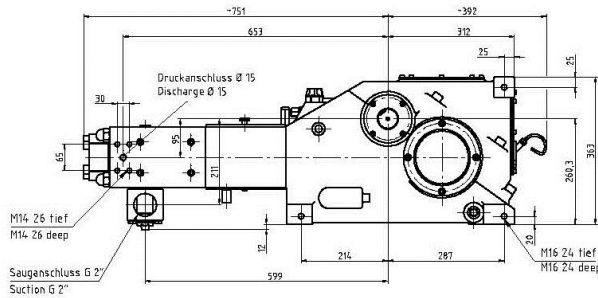

Typ M  
Type M

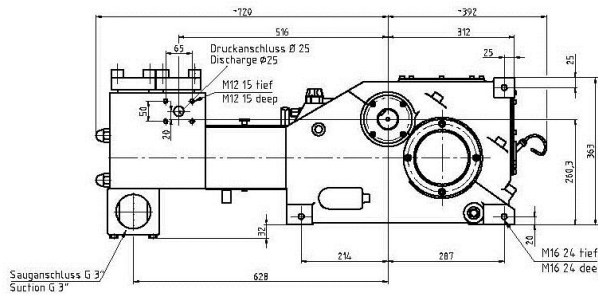

Typ MC  
Type MC

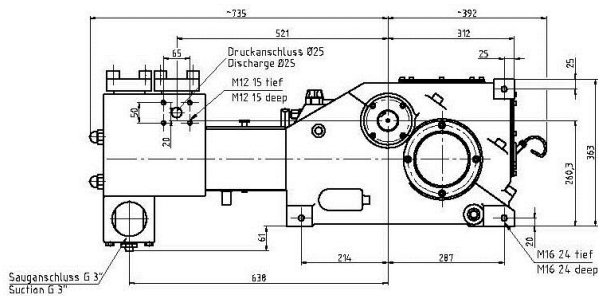

Typ MCH  
Type MCH

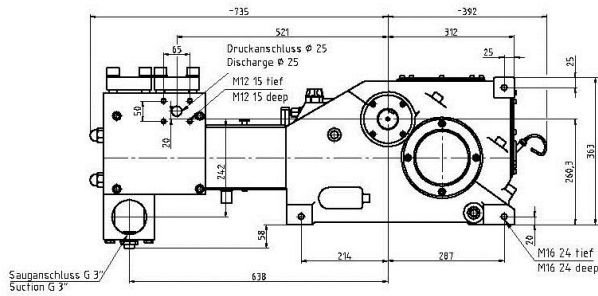

Typ A  
Type A  
≈ 1500 bar

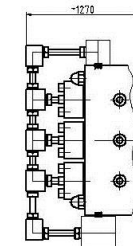

Höchstdruckkopf ≈ 1500 bar  
High Pressure Head ≈ 1500 bar

Fußmaßzeichnung  
Footprint

